

DIECI



AGRI PLUS

40.7 PS | 38.9 PS



dieci.com

PERFORMANCE

Vehicle model	AGRI PLUS 40.7 PS EVO2	AGRI PLUS 38.9 PS EVO2
Maximum capacity	4000 kg (8818 lb)	3800 kg (8378 lb)
Maximum lifting height	7,00 m (23 ft)	9,00 m (29,5 ft)
Maximum horizontal extension	3,90 m (12,8 ft)	5,85 m (19,2 ft)
Fork swiveling angle	146°	146°
Pull-out force	6000 daN (13489 lbf)	6000 daN (13489 lbf)
Towing force	8200 daN (18434 lbf)	8200 daN (18434 lbf)
Maximum climb angle	60%	60%
Unladen weight	7700 kg (16976 lb)	7900 kg (17417 lb)
Max speed (referred to wheels with maximum permitted diameter)	40 km/h (24,9 mph)	40 km/h (24,9 mph)

BOOM

Vehicle model	AGRI PLUS 40.7 PS EVO2	AGRI PLUS 38.9 PS EVO2
Lifting	6,6 s	6,6 s
Descent	3,9 s	3,9 s
Extension	5,5 s	5,5 s
Retraction	3,3 s	3,3 s
Forward swiveling	2,1 s	2,1 s
Reverse swiveling	1,3 s	1,3 s

ENGINE

Vehicle model	AGRI PLUS 40.7 PS EVO2	AGRI PLUS 38.9 PS EVO2
Brand	FPT	FPT
Nominal power	93 kW (125 HP)	93 kW (125 HP)
@rpm	2200 rpm	2200 rpm
Operation	4-stroke	4-stroke
Injection	Mechanical direct	Mechanical direct
Number and arrangement of cylinders	4, Vertical in line	4, Vertical in line
Displacement	4485 cm ³ (274 in ³)	4485 cm ³ (274 in ³)
Consumption	230 g/kWh (378,35 lb/Hp h)	230 g/kWh (378,35 lb/Hp h)
@rpm	2200 rpm	2200 rpm
Emission standard	Stage IIIA/Tier 3	Stage IIIA/Tier 3
Cooling system	Liquid	Liquid
Intake	Turbo compressor after-cooler	Turbo compressor after-cooler

DIFFERENTIAL AXLES

Vehicle model	AGRI PLUS 40.7 PS EVO2	AGRI PLUS 38.9 PS EVO2
Type of axles	2 steering, with 4 planetary reduction gears	2 steering, with 4 planetary reduction gears
Type of steering	4 wheels / transversal / 2 wheels	4 wheels / transversal / 2 wheels
Front axle	Rigid	Rigid
Rear axle	Swinging	Swinging
Service braking	Oil bath with servo brake on front and rear axle with double hydraulic system	Oil bath with servo brake on front and rear axle with double hydraulic system
Parking braking	Negative actuation with electrical control	Negative actuation with electrical control

HYDRAULIC SYSTEM

Vehicle model	AGRI PLUS 40.7 PS EVO2	AGRI PLUS 38.9 PS EVO2
Hydraulic pump type	Gear pump for power steering and movements	Gear pump for power steering and movements
Hydraulic pump capacity	180 L/min (47,6 gal/min)	180 L/min (47,6 gal/min)
Max. operating pressure	25,0 MPa (3626 psi)	25,0 MPa (3626 psi)
Distributor control	4in1 proportional Joystick	4in1 proportional Joystick

REFUELING

Vehicle model	AGRI PLUS 40.7 PS EVO2	AGRI PLUS 38.9 PS EVO2
Hydraulic system (total)	160,0 L (42,27 gal)	160,0 L (42,27 gal)
Fuel tank	180,0 L (47,55 gal)	180,0 L (47,55 gal)

TRANSMISSION

Vehicle model	AGRI PLUS 40.7 PS EVO2	AGRI PLUS 38.9 PS EVO2
Transmission type	Torque converter with Power Shift EVO 2 reversing mechanism and electric control	Torque converter with Power Shift EVO 2 reversing mechanism and electric control
Inching	With electronic pedal for controlled forward movement	With electronic pedal for controlled forward movement
Transmission gearbox	6 forward gears / 3 reverse gears with electronic control	6 forward gears / 3 reverse gears with electronic control

TIRES

Vehicle model	AGRI PLUS 40.7 PS EVO2	AGRI PLUS 38.9 PS EVO2
Standard tires	400/70x24"	400/70x24"
Optional tires	18x22.5"; 460/70R24"	18x22.5"; 460/70R24"

DIMENSIONS

Vehicle model	AGRI PLUS 40.7 PS EVO2	AGRI PLUS 38.9 PS EVO2
A	360 mm (14,2 in)	360 mm (14,2 in)
B	1475 mm (58,1 in)	1475 mm (58,1 in)
C	2750 mm (108,3 in)	2750 mm (108,3 in)
D	850 mm (33,5 in)	850 mm (33,5 in)
F	4175 mm (164,4 in)	4175 mm (164,4 in)
G	5075 mm (199,8 in)	5075 mm (199,8 in)
H	2445 mm (96,3 in)	2445 mm (96,3 in)
I	940 mm (37 in)	940 mm (37 in)
L	1820 mm (71,7 in)	1820 mm (71,7 in)
M	2260 mm (89 in)	2260 mm (89 in)
O	5185 mm (204,1 in)	5230 mm (205,9 in)
P	1320 mm (52 in)	1320 mm (52 in)
Q	3920 mm (154,3 in)	3920 mm (154,3 in)
T	200 mm (7,9 in)	200 mm (7,9 in)

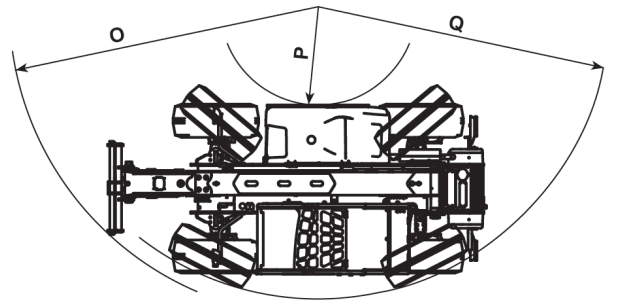
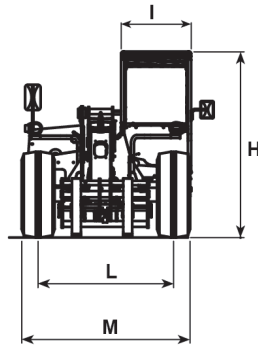
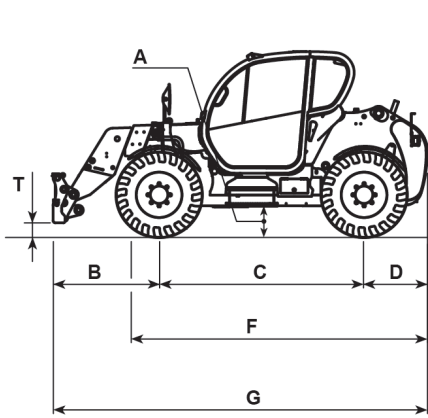

MAX 4,0 t

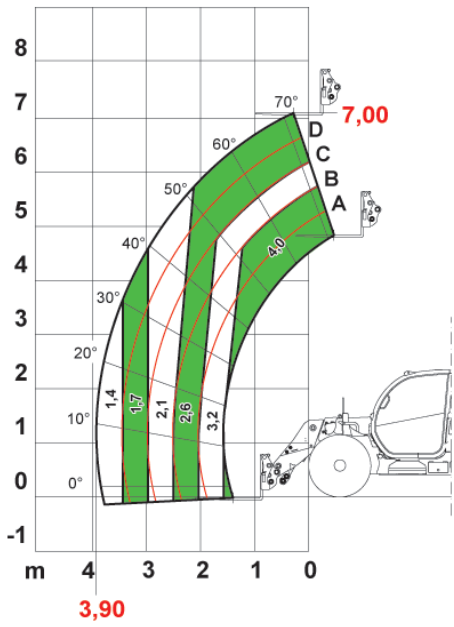

AXBI477



EN1459

40.7

MAX 3,8 t

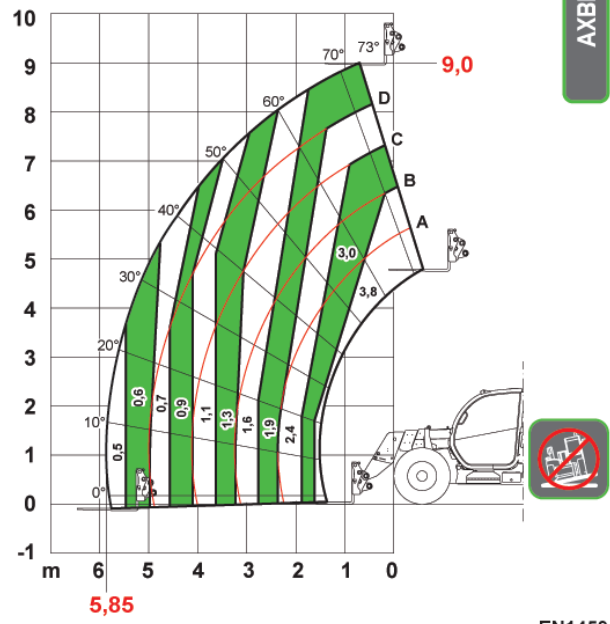

AXBI481



EN1459

38.9